

TECHNOLOGY



QUALITY CERTIFICATION ENSURES RELIABILITY

A glazed balcony is a major investment that should provide pleasure and use for many years. It is therefore vital that the products maintain high levels of quality and that the supplier is financially sound.

We at Balco take it as read that we should constantly improve and develop our products and services. As we are actively involved in the whole process from start to finish, we have close contact with customers and residents alike. We are happy to listen, because wishes and demands help us to become even better. Our constant search for intelligent solutions has also led to many exclusive patents, which make our products unique.

Goal-oriented but careful expansion has allowed us to achieve the highest possible credit rating which, together with a financially strong principal owner, makes us a stable supplier and partner. Balco's founders continue to play an active role in the company and the staff all own shares. In other words, you can be sure that we are all striving towards the same aim: for you to be happy with your choice of balcony system from Balco.



This symbol shows that the solution is unique to Balco. We have around 40 patents on small details which make the finished product so much better.



Our ISO 9001 certification guarantees that you receive a quality-assured product/service that meets whatever demands you as the customer may make. ISO 14001 means that our production is as friendly to the environment as possible.

We also follow the quality assurance system ISO 3834-2 in our welding processes for steel products.



Every year, the global company Dun & Bradstreet makes a credit assessment of Swedish companies. Over the past ten years, we have received the highest credit rating – AAA.



The symbol of the Nordic Balcony Association. As a member, we undertake to follow the association's guidelines regarding delivery of safe balconies of high technical quality.

OUR GLAZING SYSTEM

Our complete glazing system offers you plenty of options. Use the existing floor module and roof, or build from scratch. Then choose the drainage, frontage and windows. The following pages will provide a clear overview of the many combinations available.



- 1 Fixings
- 2 Floor module
- 3 Roof
- 4 Drainage
- 5 Ventilation
- 6 Frontage
- 7 Windows

1

FIXING SYSTEM



A. INCLUDED
Posts on the wall.



B. OPTION
Fixing direct to the building's concrete carcass.



C. OPTION
Post at front edge on new foundation.
Fixing to building carcass along back edge.

COMPLETE

A TOLERANT SYSTEM

Our design department makes careful calculations to ensure that the fixings and other technical details are tailored to the job in question.

The telescopic fixing allows us to compensate for any deviations in a building. It also allows safe and efficient installation.



A. INCLUDED
Hot-galvanised



B. OPTION
Choice of paint colour from the RAL scale, but not metallic.

2

FLOOR MODULE

Conditions always vary. There is usually an existing floor module that we can retain or extend. Sometimes we make a completely new one. Our floor modules are cast in a frame of hot-galvanised steel and weigh around half as much as an ordinary concrete floor. Naturally, we can also supply conventional concrete solutions and lightweight modules, if you prefer.

TOP FINISH



A. INCLUDED
Concrete

UNDERSIDE



A. INCLUDED
Concrete



B. OPTION
Painted white

COLOUR – BALCONY FRAME



A. INCLUDED
Hot-galvanised



B. OPTION
Lacquered white or grey.



C. OPTION
Choice of paint colour from the RAL scale, but not metallic.

3 ROOF

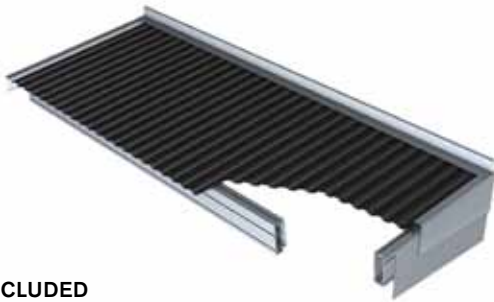

A. INCLUDED

As standard, the glazing comes integrated into an aluminium roof frame. The roof is clad in trapezium corrugated sheet metal. The colour options are the supplier's standard colours. Roof drainage system not included.

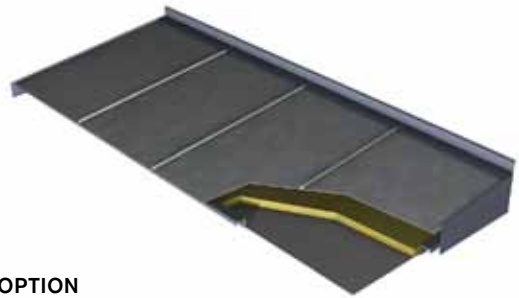

B. OPTION

Integrated aluminium roof frame. Clad in ThermiSol insulation – black on the outside, white on the inside.

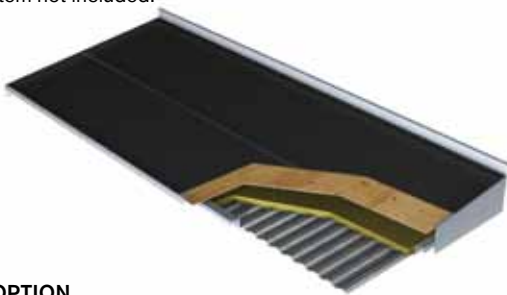

C. OPTION

Hot-galvanised steel carcass, insulated, with internal roof plating in trapezium corrugated aluzinc and external plywood plus GRP/felt.

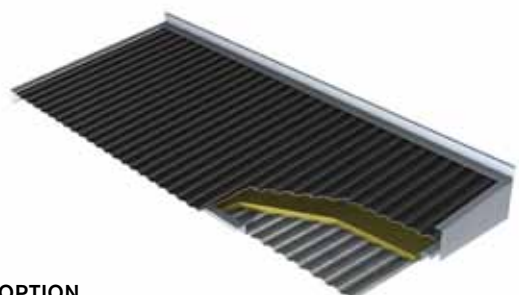

D. OPTION

Hot-galvanised steel carcass, insulated and with internal and external roof plating in trapezium corrugated aluzinc.

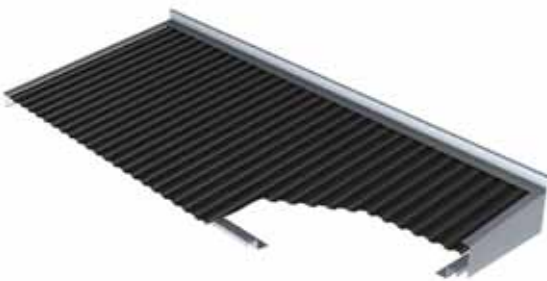

E. OPTION

Carcass of hot-galvanised steel, with roof plating in trapezium corrugated aluzinc.

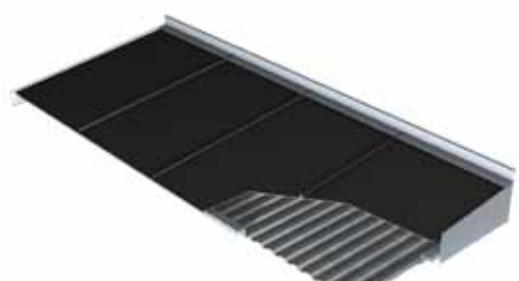

F. OPTION

Hot-galvanised steel carcass, with external standing seam roofing and internal plating in trapezium corrugated aluzinc or smooth surface.

ROOF CARCASS / COLOUR

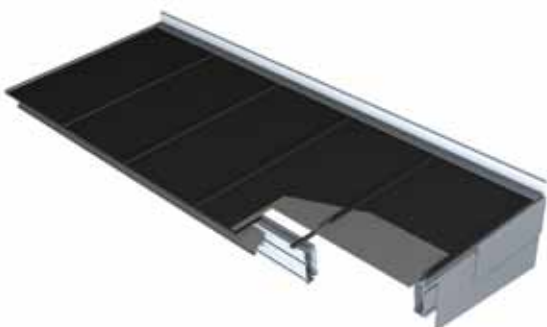

A. INCLUDED

White-lacquered aluminium carcass.



B. OPTION

Choice of paint colour from the RAL scale, but not metallic.

ROOF GUTTERING



A. INCLUDED
Drainage over front edge.



B. OPTION
With external guttering.



C. OPTION
Concealed guttering.

4

DRAINAGE SYSTEM

Drainage may not be the first thing you think about with a glazed balcony, but the right choice here will keep the cladding looking fresh for longer. With the right drainage, you avoid ugly drip marks from rain and dirty water. We have therefore developed our own patented system to lead water away along concealed channels. This may mean a higher initial cost, but it pays for itself in the long run.



A. INCLUDED
Balco BaseLine

This is a standard solution. Water is led from the track profile out over the parapet section to fall away from the front of the balcony.

Although the Balco BaseLine drainage is not unique, the fixing system is our own patent. The telescopic solution allows us to accommodate the building's own deviations. The built-in ventilation – Balco VentTech® – reduces the risk of condensation on the glass and safeguards the building's existing ventilation system.

Excellent teamed with Balco Vision™, read more on page 9.



B. OPTION
Balco CleanLine®

Patented drainage system that effectively reduces the risk of dirty streaks caused by water running down the parapet cladding. Minimised risk of water being driven inside the balcony during high winds and simultaneous underpressure on the balcony. The water is collected in the lower window track and directed along horizontal channels out to the corner posts. Along the posts' internal channels, the water is then led, floor by floor, down to the underside of the lowest balcony. Extra safety drainage is integrated into the bottom profile of the balcony section to ensure safe drainage of the floor module if someone forgets to close the windows during rain.

5

VENTILATION

All our balconies have built-in ventilation – Balco VentTech® – to reduce condensation, uncomfortable heat gain and safeguard the building’s existing ventilation system. What is more, reserve drainage is integrated into the system, which is also pre-prepared for the fitting of roller blinds.



A. INCLUDED Balco VentTech®



6

FRONTAGE

The choice of frontage determines how the balcony is perceived and functions inside and out. In addition to high quality, all our options offer gently rounded profiles and the absence of unnecessary metal parts, rivets and sealant. We also secure the parapet cladding to the front edge of the bottom profile, giving you a balcony about 100 mm deeper. All the parapets have built-in fixings for Balco's window boxes just below the sturdy rail.

A. INCLUDED Balco Sight

The stand-out feature of this option is the built-in viewing window below the track.

From inside: When sitting down and relaxing, you can still keep an eye on the outside world, thanks to the low viewing window.

From outside: Option of choosing the material in the viewing window and lower parapet for privacy etc. Balco Sight comes with laminate cladding as standard for the lower part, but a large range of other materials are also available.

Excellent teamed with Balco Vision™, read more on page 9.





B. OPTION Balco Air

This option has larger windows to give even more air and space.

From inside: This option allows you to open up a larger part of the balcony. A handrail outside the glass panes means that you can lean out comfortably and safely.

From outside: The low parapet and large windows give a huge expanse of glass. Just like Balco Sight, Balco Air comes with laminate cladding as standard in the lower part of the parapet. A wide range of other materials are also available.

Excellent teamed with Balco Vision™. Read more lower down on the page.



C. OPTION Balco Space

The whole front, with its full-height windows, is placed beyond the balcony floor and your choice of railing is fitted outside.

From inside: You can hardly get a stronger feeling of being outdoors – and the panes easily fold inwards for cleaning.

From outside: The opportunity to create unique railing solutions. With this option, a large amount of water has to be led away from each storey, so Balco Space must be combined with our unique drainage system Balco CleanLine® to avoid leakage.



D. OPTION Balco Vision

Balco Vision™ combined with a folding glass system without a frame gives the impression of a single expanse of glass.

From inside: Gives you a light outdoor room with open views – no window frames or corner posts.

From outside: A folding glass system without a frame, combined with glass corners, gives the impression of a single expanse of glass.

Can only be combined with the Balco BaseLine drainage system, coupled with folding glass, either with or without frame.

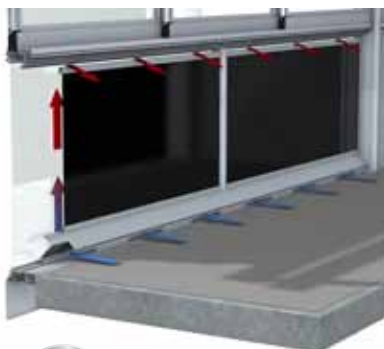

E. OPTION Balco Climate

Balco Climate helps to reduce heating bills.

Balco Climate is a glazing solution with two separate sheets of glass in the parapet – clear glass on the outside and heat-absorbing glass on the inside. Solar-powered fans sit between the glass at the bottom. The column of air between the glass is heated by the sun and when the fans start, the warm air is forced up inside the parapet. By adjusting the vent

under the track, you decide whether the air is fed into the balcony or outside. When the heated air is fed into the balcony, the input air drawn into the apartment is warmer, so less energy is required to heat the apartment. The reverse effect can be achieved when the balcony is too hot. By switching the vent, the fans will push the warm balcony air outside.



PATENT PENDING



All aluminium profiles supplied in any RAL colour, but not metallic. Extra charge for paint colour from the NCS scale.

7 WINDOWS

When choosing a window, it is important to think about how the glazed-in balcony needs to work. Do you want the balcony to open fully? From floor to ceiling? Or is the ability to shut out wind and rain the most attractive feature? Do the windows need to be cleanable from inside? Answering these few questions will make choosing the windows easier. And if you want everything in one package – choose Balco Twin®!



PATENT PENDING

A. INCLUDED Balco Twin®

With our unique Balco Twin® window, you get two systems in one for maximum flexibility and the option of opening up the whole balcony.

The elegantly designed window can be opened like a normal sliding window or folded in. Balco Twin® is simple and straightforward to operate, without any need for a strong grip or special tools. All it takes is a light grip on the window frame to slide the window to the side and when you want to fold it in, simply use the handle concealed discreetly in the window frame (optional accessory). Another unique function is the ability to fold in an individual pane at any point along the track, which is great when you want to clean your windows or chat to your neighbours.



OPTION to Balco Twin®



Remote control
(cannot be added at a later date)



B. OPTION Folding glass without frame

Has no vertical frame, so the system cannot offer the same level of protection from the elements and stability as a window with a full frame.

From outside: Gives the impression of a single expanse of glass.

From inside: The balcony is completely open when you push the panes to the side and fold them in. Window cleaning is easy.



C. OPTION Energy window

Sliding pane with double-sided energy glass that can be turned 180°.

Reversing the window creates optimum conditions for heat recovery in winter and cooling in summer.



ACCESSORIES

Our glazed balconies help give a façade a liberating consistency. To retain this impression once the balconies are in place, we recommend that you also consider the small details, many of which also provide increased comfort for those 'moving out' into their new room.



Supplementary glazing. Full-height folding system of panes with no vertical profiles from floor to ceiling. Window height max 2500 mm approx. Glazing is fitted inside the existing railing.



Integrated LED lighting. Now it is also possible to integrate a string of LED lights into the upper and lower track. This lovely balcony lighting brings added vibrancy to the building façade. *Cannot be added at a later date.*



Balco Twin® handle, no loose keys needed. Accessory for the Balco Twin® window.



Motorised windows and roller blinds. Using the remote control supplied, the resident can easily open and close the balcony windows without leaving the comfort of their chair. *Cannot be added at a later date.*



Wave flooring with studded underside. Max flooring depth 2000 mm (extra charge for depths of over 2000 mm).



Powered awning with or without wind and sun control.
Cannot be added at a later date.



Ready for roller blinds, order from the start or add later. Roller blinds are also available for the parapet. Motorised roller blinds are another option – these must be ordered at the same time as the balcony glazing.



Door with cylinder lock for balconies on the ground floor.



Window box in your choice of colour, fits onto the parapet, inside or out.

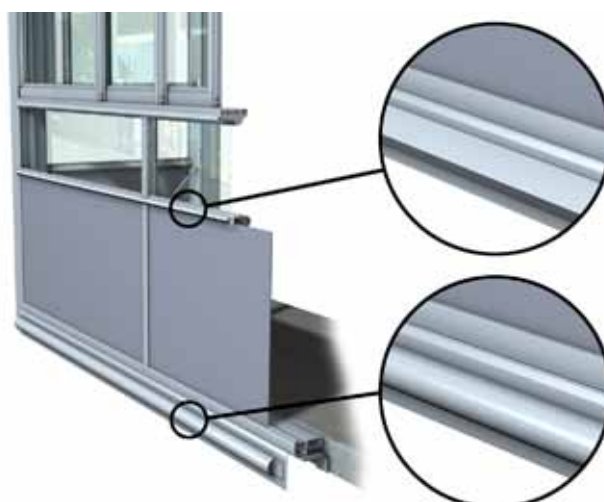

Decorative edging comes in various designs. Can also be designed specially to fit a total solution.

Balco Access[®]

A unique glazing system specially designed for access balconies. In the event of a fire, the windows open automatically, making it easier for the rescue services and increasing residents' sense of security. Four out of five windows in each section can also be opened at will.

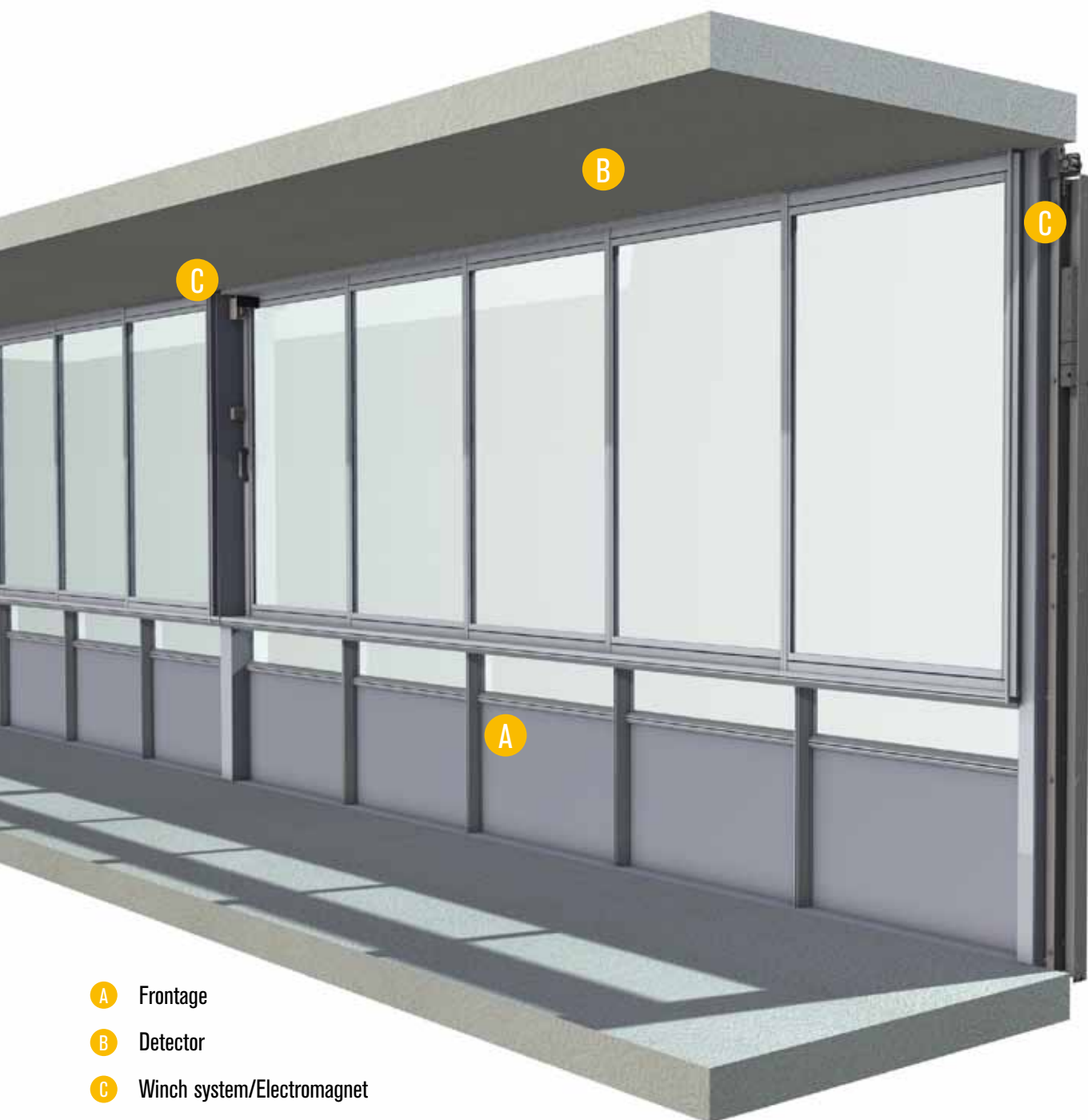

- A Frontage
- B Detector
- C Winch system/Electromagnet

The choice of frontage determines how the access balcony looks and functions inside and out.



BALCO SIGHT

The stand-out feature of this option is the built-in viewing window below the track. Read more on page 8.



BALCO AIR

This option has larger windows to give even more air and space. Read more on page 9.



SMOKE DETECTOR

If smoke forms, signals are sent from the ceiling-mounted smoke detector to an electromagnet located on each window section.



ELECTROMAGNET

When the electromagnet receives signals from the smoke detector, the force between the magnets is broken. A concealed wire system then slides the windows to the side automatically.

DRAINAGE

Choose one of our existing drainage systems on page 7.

RAILINGS & OPEN BALCONIES

We have a complete range for open balconies including railings, roofing and side screens – all offering the same quality you will find in our glazing systems. That's why we are the market leader. There are in fact no limits. Even if an apartment has no opening and floor module, it is still possible to build a balcony. Our design department has many years' experience of both possible and apparently impossible projects. Together we can try to make your wildest dreams and aspirations come true.





FLOOR MODULE

THE BALCONY FLOOR

Conditions always vary. There is usually an existing floor module that we can retain or extend. Sometimes we make a completely new one.

Our concrete floor modules are made to handle the majority of conditions and weigh around half as much as an ordinary concrete floor. The modules are cast in a frame of hot-galvanised steel.

Naturally, we can also supply conventional concrete solutions.



COMPLETE FIXING SYSTEM

A TOLERANT SYSTEM

Our design department makes careful calculations to ensure that the fixings and other technical details are tailored to the job in question.

The telescopic fixing allows us to compensate for any deviations in a building. It also allows safe and efficient installation.

2 BALUSTRADES

All our railings are made of gently rounded aluminium profiles that can be lacquered in your colour of choice – from the RAL scale as standard or from the NCS scale for an additional charge. Two of our handrails are also prepared for the fitting of a window box.

- A** Handrail
- B** Post bracket with fittings
- C** Post bracket for fitting to front edge
- D** Rail
- E** Frame profile
- F** Cladding

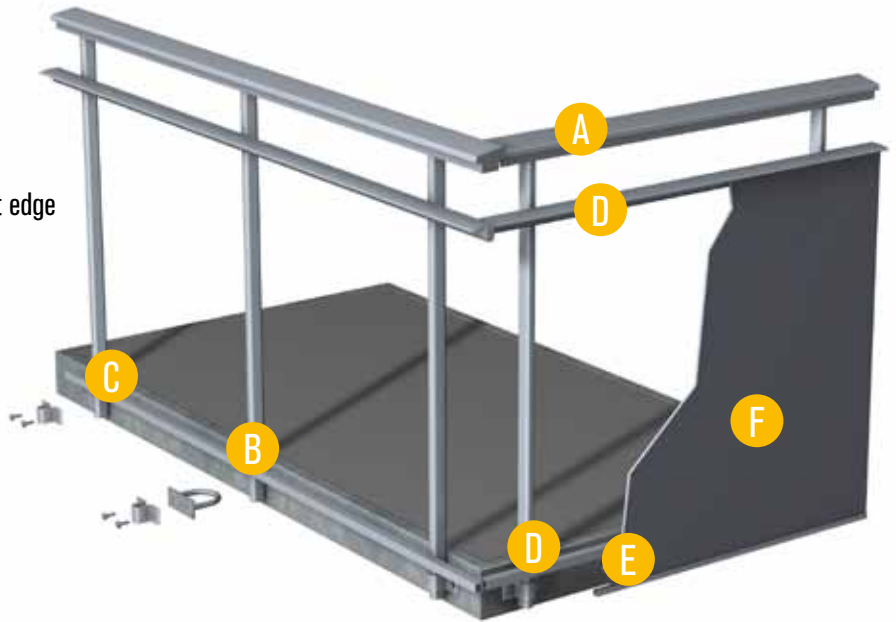

Handrail

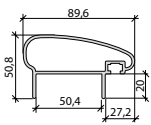

TYPE 1
Prepared for window box

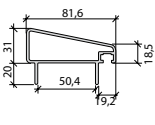

TYPE 2
Prepared for window box

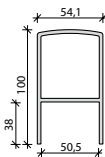

TYPE 3

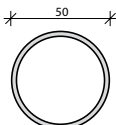

TYPE 4

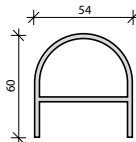

TYPE 5

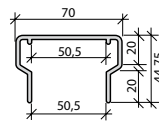

TYPE 6

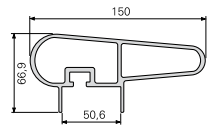

TYPE 7

Rail

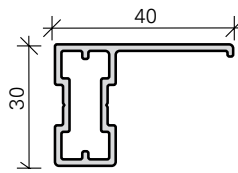
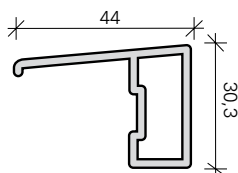
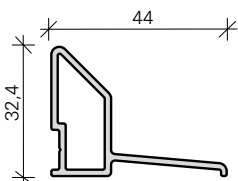

Post

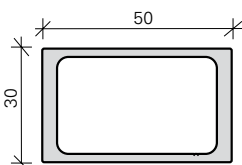

The choice of cladding is key to the balcony's appearance and the character of the whole façade. The cladding is available in a host of different colours and materials. The combination of cladding and handrail is what gives the balcony its specific look. Choose from a wide range of materials, most of which can be coloured. The cladding can be fitted internally or externally. Choosing the latter option hides the posts and the floor module.



1 Vertical trapezium corrugated



2 Sine corrugated



3 Steel panels



4 Textured



5 Perforated Aluminium Sheet



6 Laminated Board with aluminium frame



7 Cladding with decorative profiles



8 Grille railing



9 Internal glass with decorative tubing



10 Laminated glass with frame, transparent or coloured



11 Balustrade



Decorative tubing

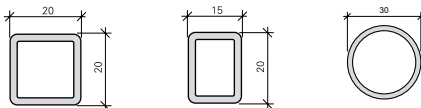

Cladding

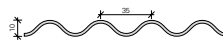

Sine corrugated sheet aluminium



Trapezium corrugated sheet aluminium

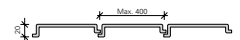

Steel panels

For glass, laminate and other sheeting

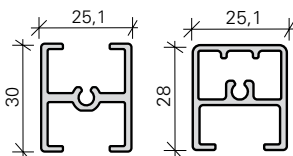

Glass and laminate frame with rubber seal

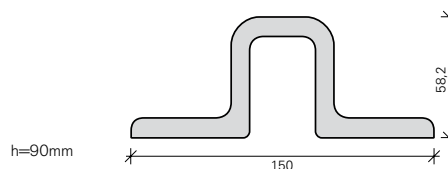

Post bracket

The need for weather protection and privacy will determine the choice of materials and design. The variations are actually endless – challenge us and see what we can do!

Separating screen

THE WALL BETWEEN TWO BALCONIES

It usually only takes a simple type of screen to create a barrier between two neighbouring balconies. The most common material is laminate or laminated glass, which is available in all sorts of variations. Let the need for screening and privacy guide your choice.



Side screen

THE OUTSIDE WALL OF THE BALCONY

Above the cladding, it can be good to screen the balcony off from wind and rain. Choose from our range of designs and materials. If you want a side screen to give added privacy, choose a material that is not transparent.



Low side screen with straight corner



High side screen

5 ROOF

The roof is designed to handle all expected loads by a wide margin. As standard, the roof is clad in foiled polycarbonate, and can be attached in many different ways, depending on the circumstances. A range of other materials are available as optional extras.



Standard roof with braces anchored in the steel posts.



Standard roof with vertical supports fixed to the balcony floor.



Cantilever roof fixed directly into the wall.



Cantilever roof fixed directly into the steel posts.

SUPPLEMENTARY GLAZING

We can create a comfortable outdoor room based around an existing railing.

CLEVER TECHNICAL SOLUTIONS AND OUR OWN PATENTS



As Balco is responsible for the entire process from development to approved final installation, you can benefit from our experience throughout. If we feel that something can be made even better, we do not rest until we have found a solution. We have therefore filed a number of unique patents over the years. These are all included when you choose to work with us.



Balco VentTech®

All our balconies have built-in ventilation – Balco VentTech® – to reduce condensation, uncomfortable heat gain and safeguard the building's existing ventilation system. What is more, reserve drainage is integrated into the system, which is also pre-prepared for the fitting of roller blinds. BALCO PATENT

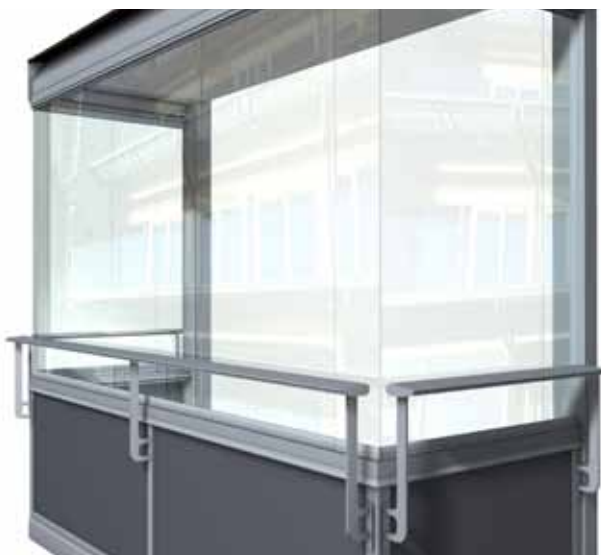

Balco Vision™

A folding glass system without a frame, combined with glass corners, gives the impression of a single expanse of glass.



Balco CleanLine® – keeps the façade clean

The water is collected in the window track and directed down to the ground via channels integrated into the aluminium frame. You get to avoid dirty water marks on the parapet, and the whole façade enjoys effective protection. BALCO PATENT



Easy to air

A small window makes it easy to get fresh air in without opening all the panes. Closed, it also acts as a lock for the other panes. BALCO PATENT



Balco Twin®

Open up the whole balcony or fold in an individual pane at any point along the track – all with remarkably little effort. Simply use the handle concealed discreetly in the window frame. BALCO PATENT



Energy window

Sliding pane with double-sided energy glass that can be turned 180°. Reversing the window creates optimum conditions for heat recovery in winter and cooling in summer.

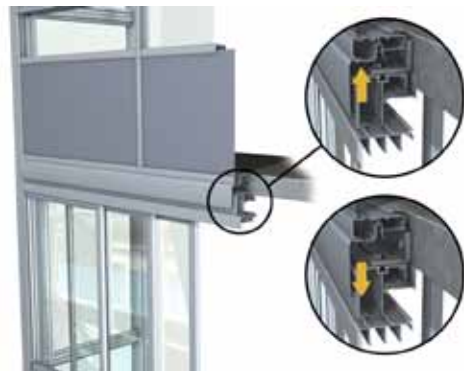

Tolerant fixings

The telescopic fixing allows us to compensate for any deviations in a building. BALCO PATENT

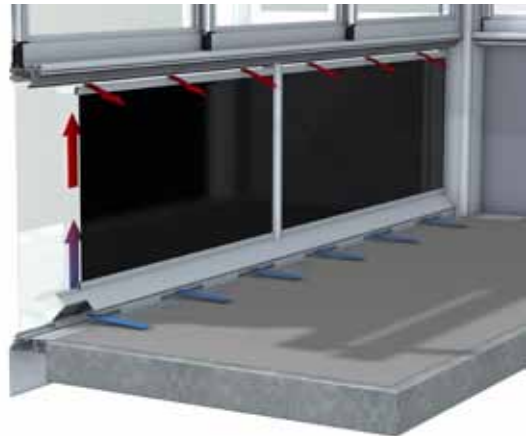

Balco Climate

Balco Climate is a glazing solution with two separate sheets of glass in the parapet – clear glass on the outside and heat-absorbing glass on the inside. Solar-powered fans sit between the glass at the bottom. The column of air between the glass is heated by the sun and when the fans start, the warm air is forced up inside the parapet. By adjusting the vent under the track, you decide whether the air is fed into the balcony or outside. When the heated air is fed into the balcony, the input air drawn into the apartment is warmer, so less energy is required to heat the apartment. The reverse effect can be achieved when the balcony is too hot. By switching the vent, the fans will push the warm balcony air outside. BALCO PATENT PENDING

Sweden (HQ)

Balco AB
Ålgvägen 4
352 45 Växjö
Phone +46 470-53 30 00
Fax +46 470-53 30 97
balco@balco.se
www.balco.se

Norway

Balco AS
Sandstuveien 60A
1184 OSLO
Phone +47 23 38 12 00
Fax +47 23 38 12 01
balco@balco.no
www.balco.no

Denmark

Balco A/S
Industriholmen 15 B
2650 Hvidovre
Phone +45 57 83 13 50
Fax +45 57 83 43 50
balco@balco.dk
www.balco.dk

Germany

Balco GmbH
Schönefelder Chaussee 233
125 24 Berlin
Phone +49 30 634 998 25
Fax +49 30 634 998 24
balco@balco.de
www.balco.de

UK

Balco Balcony Systems Ltd
Concorde House, Trinity Park,
Solihull, Birmingham
B37 7UQ United Kingdom
Phone +44 (0)800 652 4526
balco@balcouk.com
www.balcouk.com

Poland

Balco AB
ul. Sarmacka 9/39
02-972 Warszawa
Phone +48 22 412 12 22
Fax +48 22 412 12 22
poland@balco.eu
www.balco.eu